

Standard configuration

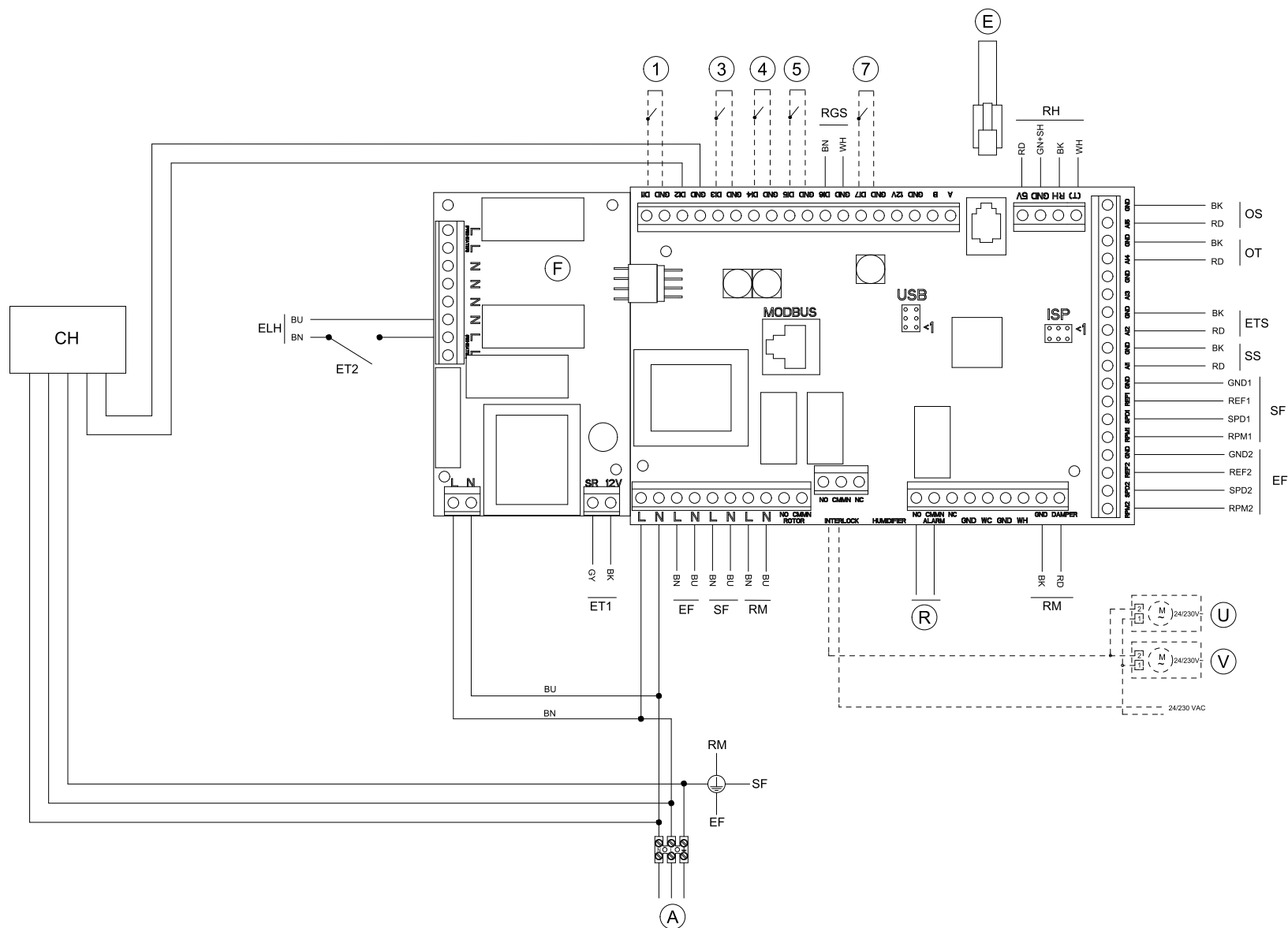

Units with HW re-heater + WC

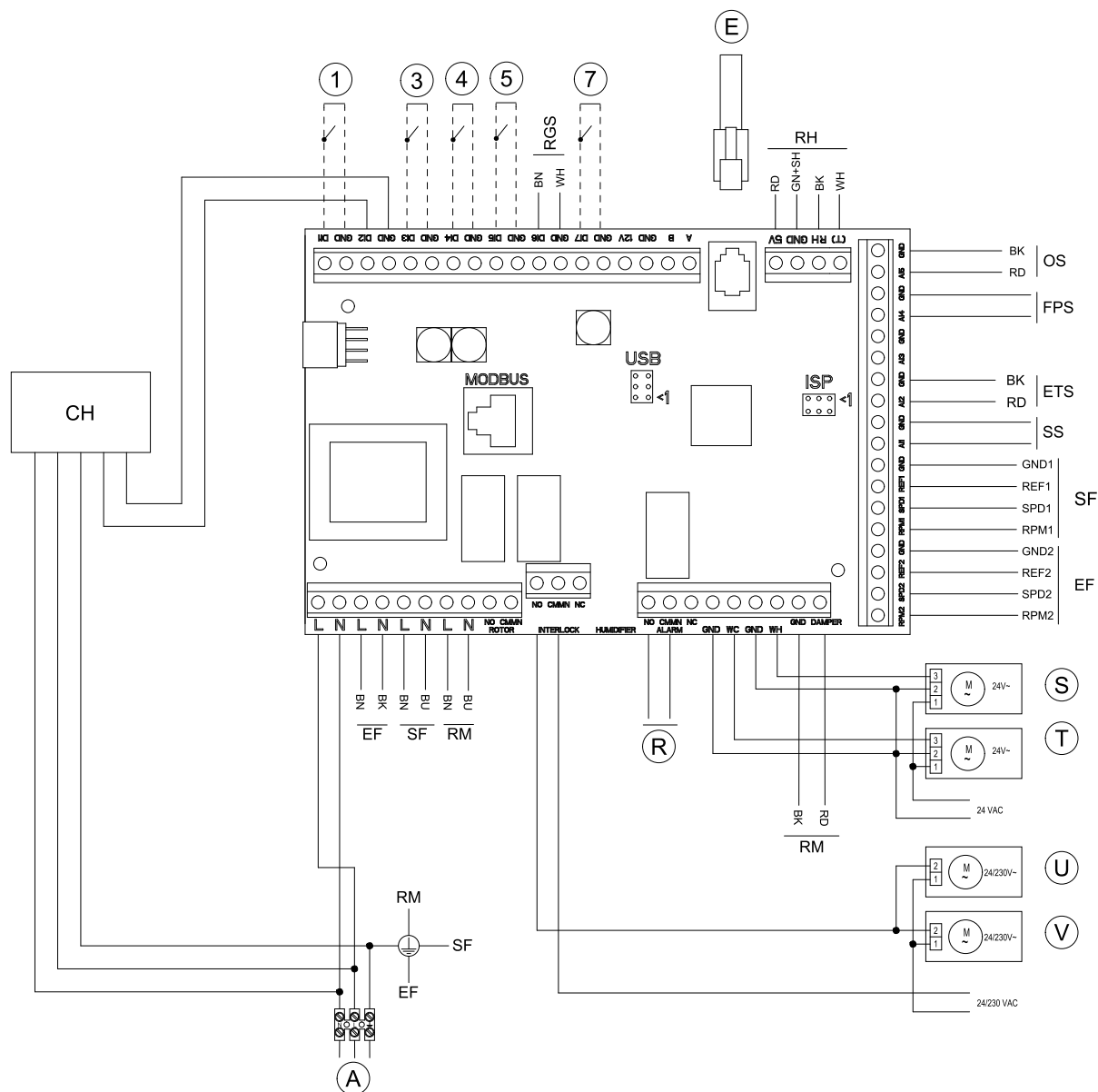

Symbol	Description
SF	Supply air fan.
EF	Extract air fan.
SS	Supply air temperature sensor. ¹
ETS	Extract air temperature sensor.
ELH	Electrical re-heater battery.
OT	Overheat protection sensor. ²
OS	Outdoor air sensor.
FPS	Frost protection sensor, type TG-A130. ³
RM	Rotor motor.
ET1	Emergency thermostat, manual reset 110°C (normally closed contact)
ET2	Emergency thermostat, automatic reset 60°C (normally closed contact)
CH	Cooker hood.
RGS	Rotor guard sensor.
RH	Humidity sensor.
A	Mains supply 230 V~.
E	External control panel.
F	Circuit board, PCU – PB. ²
R	Sum alarm, Max 24V, 1A.
S	Water valve actuator, heating.
T	Water valve actuator, cooling.
U	Damper motor Outside air.
V	Damper motor Exhaust air.
1	Fan configuration: (std.: EF = High, SF = High).
3	Fan configuration: (std.: EF = Low, SF = High).
4	Disconnected re-heater battery.
5	Extended running.
7	Home/leave.
BU	Blue.
BN	Brown.
BK	Black.
RD	Red.
YE	Yellow.
GY	Gray.

WH	White.
GN	Green.

1. For water heating/cooling battery, type TG-K360.
2. Units with electrical re-heater battery.
3. Water heating battery.